

ENGINE CONTROL UNIT

SRA-EDL4/8

Internal data logger, DBW control
High number of Inputs/Outputs
Ethernet line

Description

SRA-EDL4/8 is a dedicated Engine Control Unit. A single unit can drive up to eight injectors and six ignition coils. SRA-EDL4/8 can drive logic command coils (SW option).

SRA-EDL4/8 is an engine control unit which includes data logger and a very high speed Ethernet line to download data. Communication from the PC based configuration tool and to other units (such as dashboard and logger) is by the 2 CAN lines and an asynchronous serial line.

Inside the unit there is a high performance RISC microcontroller with a logging capability of 4 or 8 Mbyte and an FPGA for diagnostic purposes.

SRA-EDL4/8 provides analogue inputs for single-ended, differential, temperature and knock-sensor as well as an interface for a switching lambda sensor. The unit also provides an H-Bridge output stage for use with suitable "Drive by Wire" actuators.

6 configurable speed sensor inputs (inductive or Hall) provide full flexibility of configuration for engine angle detection as well as other frequency inputs such as wheel or shaft speed.

SRA-EDL4/8 is supplied with the mating connector (loom side).

Main Features

- 8 Single-ended
- 6 Pick-ups or Hall effect
- 6 Inductive or logic command ignition drivers (SW option)
- 8 On/Off injector drivers
- 1 H-Bridge: DC-Motor driver for "Drive by Wire" control
- 4 PWM (Current controlled PWM)
- 1 On/Off or Linear Lambda sensor
- 2 Knock input for detonation control accelerometers
- 4 or 8 Mbyte internal data logger
- Up to 128 logged channels
- Up to 10 Kbyte/s logging rate
- Sampling rates up to 200 Hz
- 2 CAN communication buses
- 1 Ethernet line



Benefits

- No need of external data logger
- Extremely reduce data download time by means of Ethernet link
- The logic command coils option is available on request
- SW selectable NTC/PT1000 temperature sensor
- Flexible setup by means of a high number of Inputs/Outputs
- Floating point data management
- Direct management of Marelli dashboard display
- Pick-up inputs for wheel speed and distance measurement
- Requires Wintax3 analysis software (compatible Win2K/XP)
- Requires Axon logging setup tool
- Easy to install

Typical Applications

One make race series

ENGINE CONTROL UNIT

SRA-EDL4/8

Internal data logger, DBW control
High number of Inputs/Outputs
Ethernet line

Technical Characteristics

Inputs

Analogue Single-ended	8
On/Off or Linear Lambda sensor	1
Knock sensor (multiplexed).....	2
K-type thermocouple.....	2
NTC/PT1000 temperature sensor (selectable)	4
NTC internal temperature sensor	1
V battery injector.....	1
VR Pick-ups or Hall effect.....	6
On/Off digital.....	6
Lap Trigger.....	1
“Code Load” enable pin	1

Outputs

On/Off injector drivers	8
Inductive or logic command ignition drivers (SW option) ..	6
H-Bridges	1
Lambda heater drivers.....	1
PWM	4
Low-side On/Off.....	2
Voltage references.....	2

Communications

CAN line (1 Mbit/s (*)).....	2
Ethernet line (100 Mbit/s).....	1
Serial current loop.....	1

(*) Configurable on request

Logic Core

Microcontroller (80 MIPS RISC).....	1
FPGA (50k gates)	1
Flash E2PROM (microcontroller).....	1 Mbyte
RAM memory (microcontroller)	48 Kbyte
RAM memory	512 Kbyte
E2PROM parallel	64 Kbyte
E2PROM serial	4 Kbyte
Time keeper	1

Logging

Flash disk memory.....	4 or 8 Mbyte
Logged channels.....	up to 128
Logging rate	up to 10 Kbyte/s
Sampling rate.....	up to 200 Hz

Other Characteristics

Power supply	6 to 16 V
Operating temperature range (internal)	-20 to 85 °C
Protection class.....	IP 65
Dimensions	
with connectors.....	208 x 182.30 x 42 mm
Weight (approx.)	960 g

Dimensions

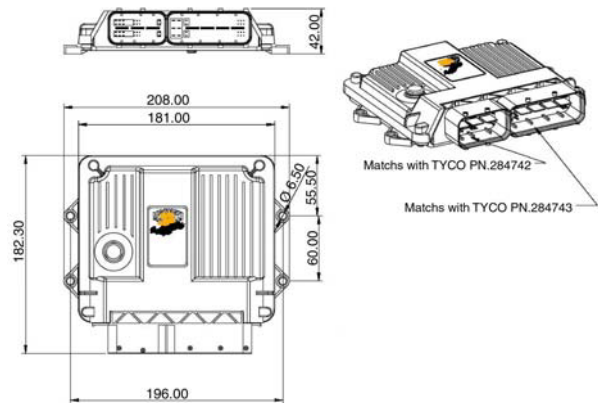

Dimensions in millimetres

Application Schematics

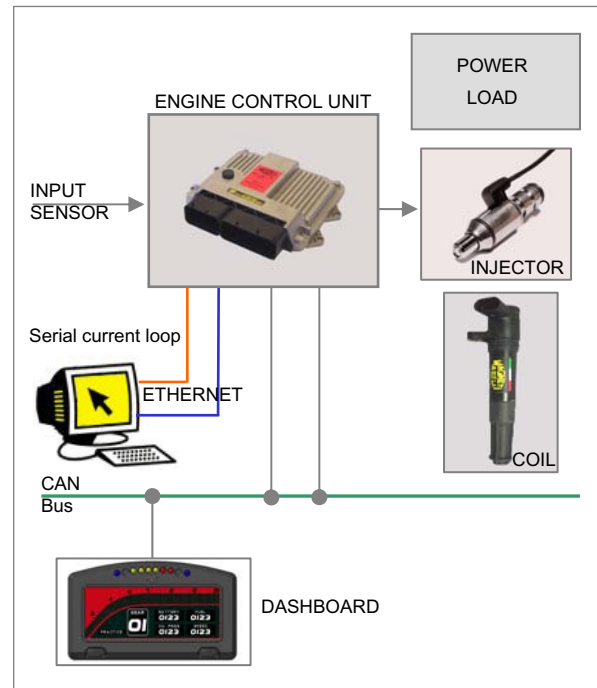

For further information, please contact:



JMR Motorsport s.c - Carrer E Nº.7 - Pol- Ind.
Pont Xetmar - Cornellà del Terri - GIRONA-
Tlf. +34 972 59 52 34 email: info@jmr-motorsport.com

October 2007
rel. 08
page 2 of 2