

## 1VM..P SERIES DIMENSIONS AND WEIGHTS AT 50 HZ, 2 POLES

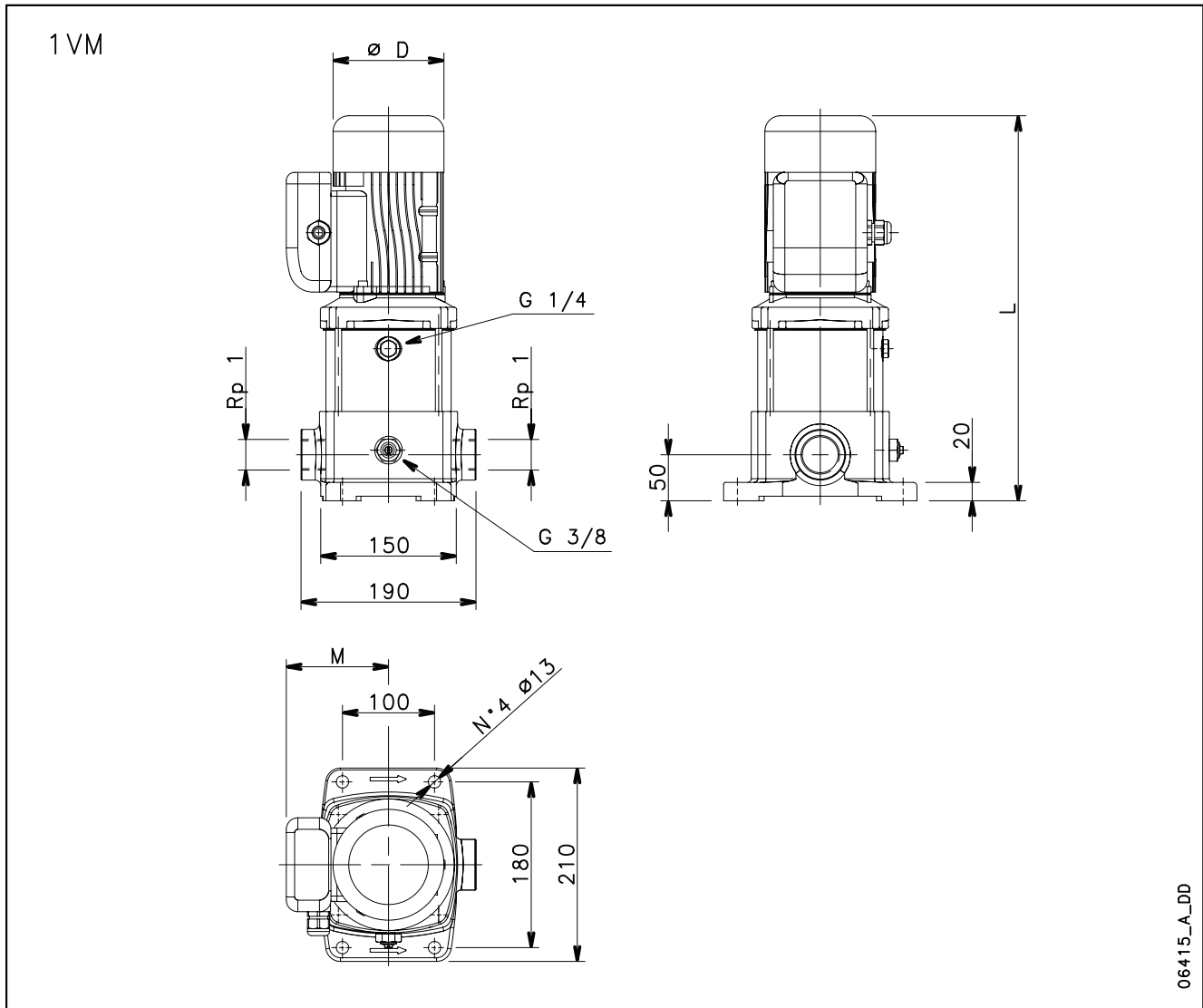

PUMP TYPE	VERSION	MOTOR		DIMENSIONS (mm)			PN bar	WEIGHT kg
		kW	SIZE	D	M	L		
1VM03	SINGLE-PHASE	0,50	63	120	111	379	10	12
1VM04		0,50	63	120	111	399	10	13
1VM05		0,50	63	120	111	419	10	13
1VM06		0,75	71	140	121	453	10	15
1VM07		0,75	71	140	121	473	10	16
1VM08		0,95	71	140	130	493	10	17

1VM02	THREE-PHASE	0,30	63	120	111	379	10	11
1VM03		0,30	63	120	111	379	10	11
1VM04		0,40	63	120	111	399	10	12
1VM05		0,50	63	120	111	419	10	13
1VM06		0,75	80	155	129	497	10	18
1VM07		0,75	80	155	129	517	10	19
1VM08		1,1	80	155	129	537	10	20

1vm-2p50-en\_a\_td