

# INT69 B2<sup>®</sup> Motor protector

## INT69 B2<sup>®</sup>



INT69 B2

### Application

Motor protection based on PTC sensors is one of the most effective and reliable protective measures against thermal overload in electrical machines. The protection unit is composed of the INT69 B2 motor protector and the PTC sensors. Due to its compact construction, the INT69 B2 is suitable for installation in electrical devices or in the terminal boxes of electrical machines.

### Functional description

At the measuring circuit input of the INT69 B2, it is possible to connect up to nine DIN 44081, DIN 44082 conform PTC sensors. Sensors with different nominal response temperatures may be used. Thus it is possible to monitor several measuring points with only one INT69 B2 motor protector.

If the temperature in one of the monitored parts or sections reaches the nominal response temperature of the respective PTC sensor, the sensor becomes highly resistive and the motor protector switches off. After cooldown, restarting is only possible if the electronic lock of the output relay is released by interrupting the voltage supply. Ex works the lock-out bridge is installed at terminals B1-B2. Alternatively the locked version can be changed to an unlocked version by removing bridge B1-B2. In that case the device switches itself on again after the cooldown.

The relay's switching output is a potential-free changeover contact. This circuit works in accordance with the closed-circuit principle, i.e. even in the event of a sensor or cable break, the relay returns to its rest position and switches off.

The sensor, relay and supply current circuits are galvanically isolated from each other.

**⚠** The mounting, maintenance and operation are to be carried out by an electrician. The valid European and national standards for connecting electrical equipment and cooling installations have to be observed. Connected sensors and connection lines that extend from the terminal box have to feature at least a basic insulation.

See back side for further specifications

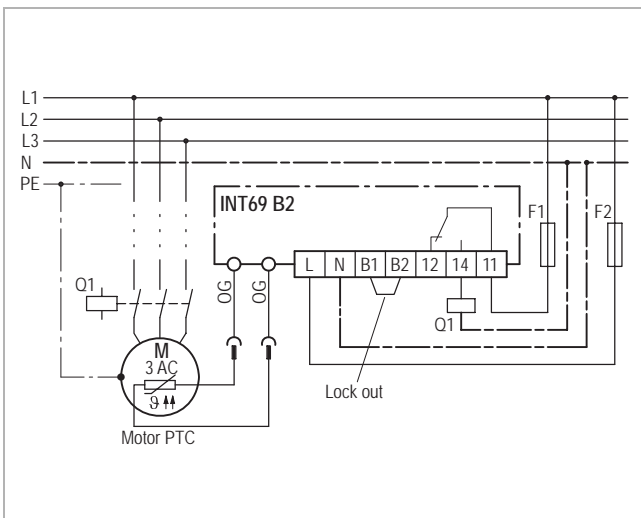

Wiring diagram

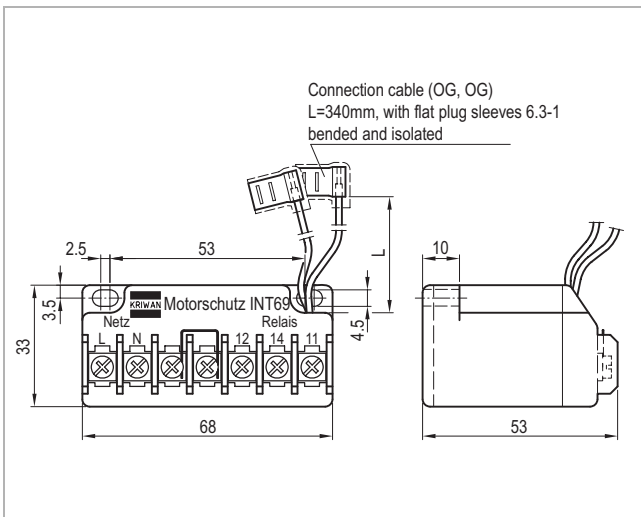

Dimensions in mm

Technical changes reserved



**INT69 B2®**

# INT69 B2® Motor protector

## Technical specifications

Supply voltage	AC 50/60Hz 115-230V ±10% 3VA
Permitted ambient temperature	-30...+70°C
Temperature measuring circuits	
- Type	1-9 PTC sensors acc. to DIN 44081, DIN 44082 in series
- $R_{25, total}$	<1.8k $\Omega$
- $R_{trip}$	4.5k $\Omega$ ±20%
- $R_{reset}$	2.75k $\Omega$ ±20%
- Max. length connection line	30m
Resetting the lock	Main reset >5s only possible if there is no error current
Relay	
- Contact	AC 240V 2.5A C300 at least AC/DC 24V 20mA
- Mechanical service life	Approx. 1 million switching cycles
Protection class acc. to EN 60529	IP00
Connection type	Flat plug sleeves (PTC), screw terminals
Housing material	PA glass-fibre-reinforced
Mounting	Can be snapped onto 35mm standard rail acc. to EN 60715 or screw mounted
Dimensions	Refer to dimensions in mm
Weight	Approx. 200g
Check base	EN 61000-6-2, EN 61000-6-3 EN 61010-1 Overvoltage category II Pollution level 2
Approval	UL File No. E75899 cURus
<b>Order data</b>	
INT69 B2 Motor protector	<b>22 A 608</b>
Accessories and application information	see <a href="http://www.kriwan.com">www.kriwan.com</a>