

PRESSURE REGULATORS

RPM 58...74

Fuel pressure regulators
350 to 500 kPa - 5 to 300 L/h

Description

The RPM series is a family of constant fuel regulating devices for fuel-rail co-axial mounting.

The regulator comprises a sealing valve joined to an elastic membrane which by means of a compression spring compensates the pressure inside the regulator, adjusting the fuel flow.

The body and the cover are made of stainless steel, as are all internal parts in contact with fuel, the membrane is fabric-reinforced vulcanized-rubber.

A version is available that is compatible with methanol fuels.

Main Features

- Fast response
- Very good precision
- Good integration
- Can be installed on the engine or in the tank

Benefits

- Little dimensions
- Low weight
- Cost effective solution



Typical Applications

In circuit and rallies medium level
SBK & motorcycles race

PRESSURE REGULATORS

RPM 58...74

Fuel pressure regulators
350 to 500 kPa - 5 to 300 L/h

Dimensions

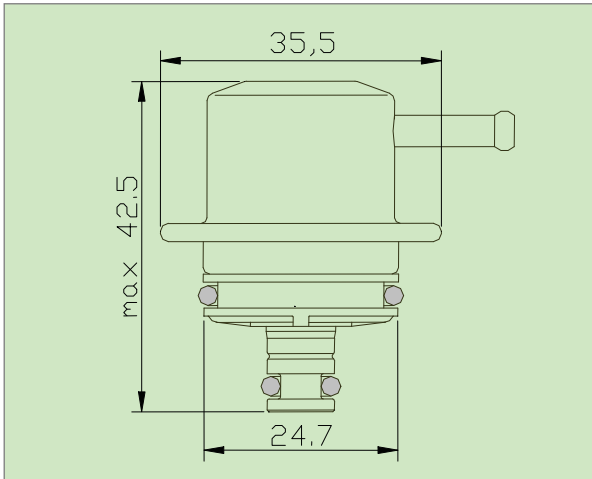

Dimensions in millimetres

Application Schematics

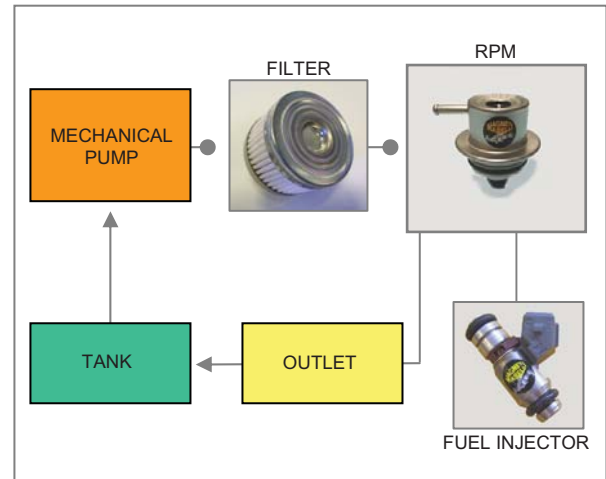

Technical Characteristics

- Set up pressure range 350 to 500 kPa
- Flow range 5 to 300 L/h
- Adjustment slope (20 L/h to 170 L/h)..... < 0.2 kPa/(L/h)
- Max. vibration (peak) 30 g
- Temperature range -10 to 110 °C
- Fuel filter mesh dimension 100 µm
- Fuel commercial and F1
- Weight 37 g

Fuel pressure regulator	RPM58	RPM73	RPM74	
Nominal pressure	350	450	500	kPa
@ Flow rate	80	80	80	L/h
Methanol resistant	no	yes	yes	

For further information, please contact:



JMR Motorsport s.c - Carrer E Nº.7 - Pol. Ind.
Pont Xetmar - Cornellà del Terri - GIRONA-
Tlf. +34 972 59 52 34 email: info@jmr-motorsport.com

October 2007
rel. 05
page 2 of 2